

UMI (Universal Metering Interface)

Overview



Cambridge Consultants Ltd
Science Park
Milton Road
Cambridge
England CB4 0DW

Tel +44 (0)1223 420024
Fax +44 (0)1223 423373
Registered No: 1036298 England

Cambridge Consultants Inc
101 Main Street
Cambridge MA 02142
USA

Tel: +1 617 532 4700
Fax: +1 617 737 9889
umi@CambridgeConsultants.com
www.CambridgeConsultants.com

UMI and the UMI logo are trademarks of Cambridge Consultants Ltd.

Subject: UMI® (Universal Metering Interface) Overview

1	Introduction	3
2	Application in a Smart Metering System	4
3	Key Features	4
4	UMI Open Standard	5
5	UMI Alliance	6
6	UMI Certification	6
7	Technical	7
7.1	Topology and Power	7
7.2	Mechanical	9
7.3	Electrical	10
7.4	Link and Application Layers	10
7.5	Security	11
7.6	Security Schemes	12
7.7	UMI codes and data objects	13
8	Benefits	14
8.1	Comprehensive solution	14
8.2	Device Manufacturers	14
8.3	Energy Suppliers	15
8.4	Smart meter rollouts	15
9	UMI Software	16
10	What next ?	18

Subject: UMI® (Universal Metering Interface) Overview

1 Introduction

UMI (Universal Metering Interface) is a new low power board-to-board wired interface. UMI (pronounced ‘you-me’) has been developed by Cambridge Consultants. UMI is primarily aimed at the complex system of networks and devices that are part of Smart Metering Systems, including :

- Smart Meters (Electricity, Gas, Water, Heat)
- Displays
- Gateways
- Appliances
- Communications modules (wireless and wired) for all the above products

Smart metering product developments face the challenge of communications standards which differ between market regions and are not yet finalised by the relevant national authorities. UMI solves this problem by separating the metrology and communications functions and defining a standard module format for the communications with a wired connection to the meter. This unbundling is useful because the metrology standards and regulations (e.g. MID in Europe) are stable. It allows the same approved base meter (or display or gateway or appliance) to be used with different communications modules which meet the national standards and specific requirements from energy suppliers.

Future upgrade of communications during the lifetime of a meter is also a requirement. Communications standards and infrastructure will evolve and the service providers (particularly for the Wide Area Network) may change and require a different connection to the home. New UMI communications modules can be developed and fitted in the field to upgrade the meter (or gateway or display or appliance). The in-field upgrade capability of UMI can also allow manufacturers to develop smart-ready MID-approved meters now by including one or more UMI ports. These meters can be installed in the field now, and the communications module fitted later when the standard is defined.

UMI is aimed at ultra low power applications. Typical battery-powered products may have an average current consumption of 15uA at 3V.

UMI has already been adopted by :

- Elster in domestic gas meters.
- Telegesis in ZigBee modules.
- Shitek in GSM modules.
- and others including Wireless M Bus and WiFi

If you would like to implement a UMI port in your product or communications module, you can get more information from :

www.CambridgeConsultants.com/umi

Subject: UMI® (Universal Metering Interface) Overview

2 Application in a Smart Metering System

The diagram below shows how UMI may be used in a typical national Smart Metering system. This example is for the UK.

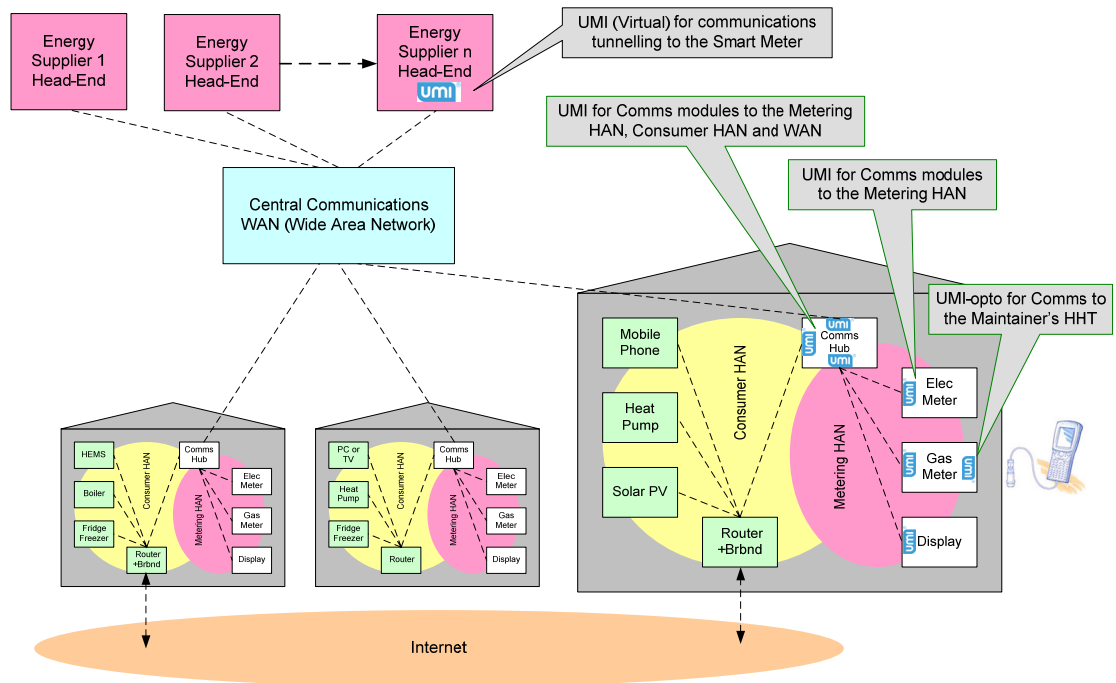

3 Key Features

The key functionality provided by UMI includes:

- A module definition suitable to implement a wide range of wired and wireless communications standards. For example ZigBee, M-Bus, WiFi, GPRS and PLC.
- A method of mapping manufacturer's meter data to industry standard data definitions such as ZigBee Smart Energy and DLMS.
- Software upgrade which is robust, secure and authenticated.
- On Smart Meters, access across the FLAG opto-port (EN62056-21) for use during meter manufacture, installation and service/upgrade.
- Power management to achieve the very low power consumption required for battery powered products such as gas meters. This includes safe and recoverable shut down in the event of power failure and in-field battery replacement

Subject: UMI® (Universal Metering Interface) Overview

- Authentication and Security with NIST/FIPS approved algorithms and methods for: authenticating access, signatures and encryption. This includes both symmetric AES-128 and asymmetric ECC-256 primes based schemes. This security enables:
 - Managed access to the meter based on roles and certificates. Users have permissions to access certain data in the meter. The permissions can be change and revoked.
 - True end-to-end security with data objects signed and encrypted inside the metrological seal and only checked and decrypted at the head-end. No reliance on the security of intermediate links. Remote devices like the head end computers or a service engineers PDA terminals are enabled as UMI virtual devices making UMI a system wide solution.
 - With the asymmetric scheme there are no shared secrets. This simplifies and de-risks secure key management.

4 UMI Open Standard



® UMI is an open standard. At present Cambridge Consultants is the caretaker for UMI (members, licence agreements, specifications, approvals, logo, trademarks, etc). In future these responsibilities will be taken over by the independent UMI Alliance.

Principles for UMI are :

- There are no licence fees for using UMI.
- UMI specifications are available.
- UMI should be implemented in full, not in part.
- UMI is tightly controlled to prevent divergence. All UMI Peripherals must work with all UMI Hosts (subject to; low and high power variants, data object access rights, and security keys).
- Products must be certified before displaying the UMI Logo and being sold.

The UMI specifications can be downloaded for evaluation from :

www.CambridgeConsultants.com/umi

Organisations wishing to manufacture and sell a UMI product must sign the UMI Licence Agreement. Please email umi@cambridgeconsultants.com to request a copy. This agreement is used to ensure that licences comply with the specifications and will adhere to the principles of the Alliance when it is formed

There no fees or other charges associated with either of these or for the on-going manufacture and sale of UMI products. The Standard is free.

Subject: UMI® (Universal Metering Interface) Overview

5 UMI Alliance

UMI will be promoted and managed by the UMI Alliance to ensure interoperability of smart metering equipment and modules. UMI will be recognised as a mark of confidence that smart metering equipment can be upgraded with new plug-in modules as the energy industry evolves its communications and data infrastructure.

The UMI logo may only be displayed on saleable products that have been certified to ensure interoperability and compliance with the specification.

The principles of the Alliance are:

- The UMI Alliance shall be formed as a Company Limited by Guarantee and its the articles shall state that the UMI Alliance is a not for profit organisation.
- The founding members of the Alliance will establish the organisational and management structure for the Alliance.
- UMI Licensees will be required to pay annual membership fees to fund the ongoing management of the organisation.
- To promote UMI and encourage other organisations to join the UMI Alliance and work for the benefit of all members in the industry
- To manage and develop the UMI Specification including its adoption by national and international standards bodies.
- To define and manage the process for certifying products as being compliant with the UMI specification.

The Alliance will be formed when UMI licencees wish to do so. At this time Cambridge Consultants will transfer ownership of the UMI Specifications, Trademarks, Logo and existing licence agreement to the Alliance.

6 UMI Certification

The UMI certification body will be managed and established by the UMI Alliance.

Devices will not be able to use the UMI logo or be declared as UMI devices until the UMI certification body has verified that the device passes all the UMI compliance tests.

In the interim period, before the UMI Alliance is formed, Cambridge Consultants can provide compliance testing and help you develop your UMI products by providing Design Services and pre developed UMI software stacks.

We expect these to also be available from other suppliers in future.

Subject: UMI® (Universal Metering Interface) Overview

7 Technical

UMI consists of 3 specifications :

- 1 UMI-spi. Document UMI-S-001. A module interface based on SPI. This has been optimised for ultra low power systems.
- 2 UMI-opto. Document UMI-S-002. An opto Interface based on EN62056-21 (FLAG port)
- 3 Security Document UMI-S-004. A security interface based on ECC-256 primes (as used in European ePassports) and AES-128.

The UMI specification (UMI-S-001) maps UMI to the OSI 7-layer communications model. It provides a full definition :

- Mechanical
- Electrical (SPI signals at 2.7V-3.6V over 10-IDC connector)
- Logical :
 - Link layer packets
 - Application layer packets
 - Access Control
 - Security
 - Data objects and UMI codes

7.1 Topology and Power

UMI has a star network topology like USB. UMI has much lower power consumption than USB. UMI operates rather like a ruggedised version of the SD card interface.

There is one UMI Host which can connect to 0-15 UMI Peripherals. The UMI Host is always powered and contains a UTC real time clock. The Host has a separate 10-IDC connector for each UMI Peripheral :

- Female for direct board-to-board connections.
- Male for indirect connections via ribbon cable.

The UMI Host has one UMI Port for each UMI Peripheral. UMI Ports can be high power (1A at 12V) or low power (50mA at 3V). The UMI Host can have any mixture of high power and low power UMI Ports. A battery-powered device such as a gas meter will only contain low-power UMI Ports. A mains-powered device such as an electricity meter or a gateway may contain high-power and low-power UMI Ports.

There are three types of UMI Peripheral :

- High power. Can only be plugged into a high-power UMI Port. Peak power is 1A at 12V from UMI_HVDD. This could be a GSM module (GPRS, SMS or UMTS).

Subject: UMI® (Universal Metering Interface) Overview

- Low power. Can be plugged into a low-power or high-power UMI Port. Peak power is 50mA at 3V from UMI_VDD. This could be a ZigBee, KNX, Z-Wave, Wavenis, Bluetooth or Wireless M-Bus module.
- Self powered. Can be plugged into a low-power or high-power UMI Port. This could be Wired M-Bus, Wired KNX, PLC (power line communications) or a battery powered GSM or UMTS module (that could be used in a gas meter).

The connector & physical form factor are the same for all the above UMI Peripheral types. High power UMI devices connect the UMI_HVDD pin, others do not.

The Host provides a switched power supply to each Peripheral. The signal level is defined by UMI_VDD. UMI_VDD is also used as the power supply in low power UMI Ports. UMI_HVDD is used as the power supply in high power UMI Ports. The Host must turn the power supply off when a Port is unused and when a Peripheral is changed (unplugged or plugged in).

When a UMI Peripheral is moved from one UMI Host to another, it may need some software changes, but will not require any hardware changes (mechanical or electrical).

The following diagram shows an example product that contains 5 UMI Ports :

- One internal (board-to-board) low power Port.
- Two external (ribbon cable) low power Ports.
- One external (ribbon cable) high power Port.
- One Opto port (EN62056-21 or FLAG port)

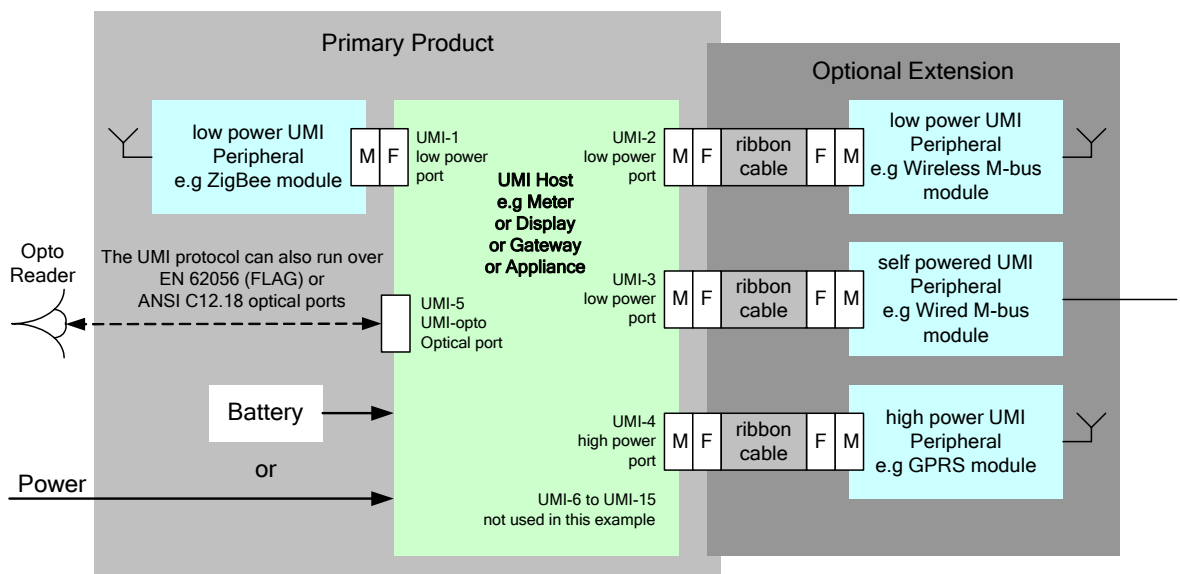

Subject: UMI[®] (Universal Metering Interface) Overview

7.2 Mechanical

The UMI Peripheral PCB must conform to the following mechanical dimensions :

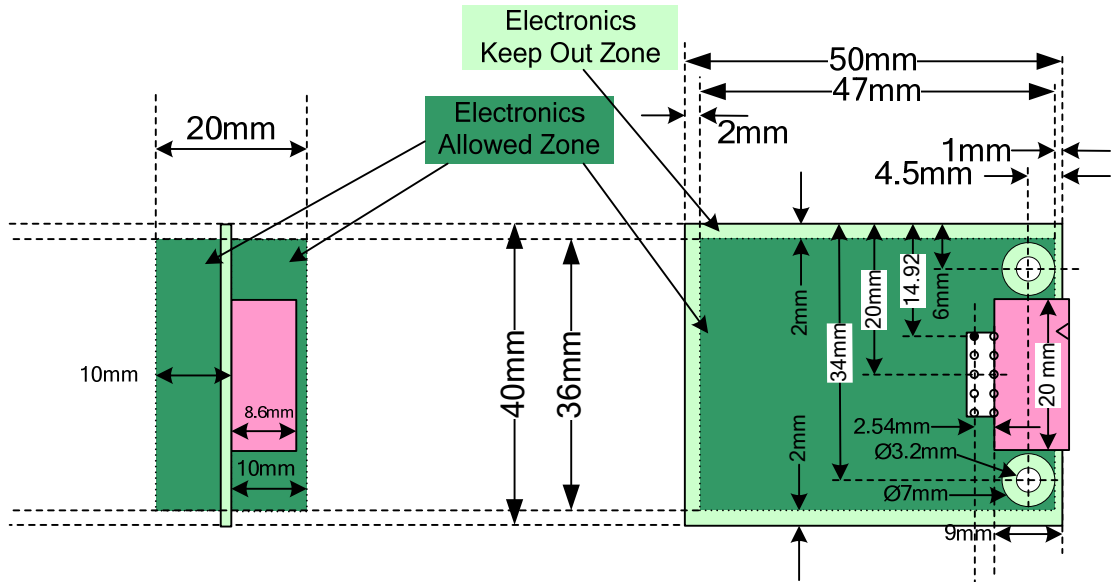

Here is an example of a UMI Peripheral.



Subject: UMI® (Universal Metering Interface) Overview

7.3 Electrical

The UMI connector is a bump-polarised 10-IDC (2.54 mm pitch). It is a right-angle male on the UMI Peripheral. It is a right-angle or straight, male or female for each UMI Port in the UMI Host. The pinout is as follows :

Pin	Name	Type	Direction at UMI Host	Description
1	UMI_VDD	Power	-	Signal voltage level from Host to Peripheral. Also used as power supply to low power Peripherals.
2	UMI_MISO	SPI	Input	SPI data from Peripheral
3	UMI_HVDD	Power	-	Power supply to high power Peripherals. Not connected in low power Host Port or low power Peripheral or self-powered Peripheral (just a capacitor to GND in these cases).
4	UMI_MOSI	SPI	Output	SPI data from Host
5	GND	Power	-	0V
6	UMI_CLK	SPI	Output	SPI clock from Host
7	GND	Power	-	0V
8	UMI_CSB	SPI	Output	Chip select from Host, active low
9	UMI_INTB	IO	Input	Interrupt from Peripheral Normally high Negative and Positive edges are active
10	UMI_RSTB	IO	Output	Reset from Host, active low, open drain

The signals are all digital, driven at 0V or UMI_VDD (which is 2.7V to 3.6V).

7.4 Link and Application Layers

UMI has a packet protocol for Link and Application layers. UMI transactions consist of a Command and a Response. The Command can be initiated by the Host or by the Peripheral. This means that although UMI is physically a hierarchical star network, it is operated logically as a peer-to-peer network (between the Host and Peripherals). UMI transactions include error detection and reporting.

Subject: UMI® (Universal Metering Interface) Overview

7.5 Security

UMI operates an authentication scheme and uses certificate signatures. Every UMI data object has its own read and write access levels. These are set so that access requests are authorised or rejected as appropriate for various individuals and organisations (e.g Meter Operators and Energy Suppliers).

UMI is designed to transport legally relevant metrological (and other) data between UMI Devices (for example, between a communications module and a host within a Smart Metering Device) and between UMI Devices and the larger Smart Metering System within which it operates.

As part of UMI security, every UMI Node (UMI Device or UMI Virtual Device) has a unique 64-bit identifier called the UMI ID (this is an IEEE EUI-64 number).

Below the main functions in the security scheme are summarised and the following section provides a summary of the security schemes that are supported.

Encryption

Application layer encryption is supported in the UMI protocol.

Authentication

Authentication is supported in the UMI protocol. A UMI Device may require a peer UMI Device to authenticate itself before being granted access to its application services. Link layer forwarding may be disabled until the sending UMI Device has authenticated itself with the UMI Host.

Command Signatures

A UMI Node can apply a Command Signature to any application packet command. This authenticates the Commander to a specific UMI security Role for that one command only. This is necessary if the Responder requires that Role for the requested operation. This is often used for a Write Object command.

Response Signatures

A UMI Node will apply a Response Signature to an application packet response if the previous command requested it. This proves the authenticity of the response. This is often used in a Read Object response.

Image Signatures

A UMI Node can apply a signature to an Image (e.g software upgrade). E.g a UMI Virtual Device in the Smart Metering System can supply a signature with an Image it wants to write to a UMI Device. The signature contains a message authentication code, which is derived from the image using cryptographic techniques.

Subject: UMI® (Universal Metering Interface) Overview

7.6 Security Schemes

A UMI Security Scheme defines algorithms and data structures for Authentication, Command Signatures, Response Signatures, Image Signatures, Key Exchange and Encryption at Application Layer. All UMI security is applied at the UMI Application Layer, none at the UMI Link Layer.

A UMI Device must support Scheme 0. It can support as many other Schemes as it wants, however it must not support partial Schemes.

Most devices will implement only one Security Scheme (in addition to Scheme 0); complex devices may implement several Security Schemes.

A UMI Virtual Device can just support the parts of a UMI Security Scheme that it needs. e.g only Scheme 2 Image Signatures.

The following table shows an overview of the currently defined Security Schemes.

	Scheme 0	Scheme 1	Scheme 2
Key Establishment	None	Shared secret	ECDH master key with HMAC-SHA-256-128 to derive AES session key
Authentication (in scheme 2 this is Key Confirmation)	None	Challenge-Response	Encrypted no-operation
Data Encryption	None	None	AES-128 GCM mode using session key
Image Encryption	None	None	ECEIS-KEM generated Transport Key with AES-128 GCM mode encryption
Signatures	None	AES-128 MAC	ECDSA-SHA256
Session Key	No	No	Yes
Certificates	No	No	Yes

UMI security is fully defined in the UMI Security Specification (UMI-S-004).

Subject: UMI® (Universal Metering Interface) Overview

7.7 UMI codes and data objects

Each UMI data object is identified by a 32-bit UMI code of the form :

- umi.byte3.byte2.byte1.byte0 Each byte is a decimal number, 0-255.
- e.g, umi.1.23.1.103

A UMI data object has one UMI code and can be any of :

- A basic data type (integer or string)
- A structure (of basic data types)
- An array (of basic data types)
- An array of structures

Members of the UMI Alliance are allocated a bank of 64k UMI codes which they can use as they please. e.g a company might be given the UMI bank, umi.1.23. We recommend that the company allocates banks of 256 UMI codes to each new UMI device they develop, e.g umi.1.23.0 for their first UMI device and umi.1.23.1 for the next. The development project team can then allocate the 256 UMI codes to data objects in their device as they please, e.g umi.1.23.1.103.

This scheme does not require ‘manufacturer-specific’ UMI codes. UMI codes will not clash because they are hierarchically managed by the UMI Alliance, the Manufacturers and the project teams. Devices will not be UMI-certified if they use UMI codes outside their allotted UMI banks.

This scheme does mean that some logically-equivalent data objects will be allocated different UMI codes from one manufacturer to another. This does not matter as every UMI Peripheral will translate their UMI codes (from the Peripheral and Host) as required for the particular communications standard being implemented, e.g :

- A ZigBee module may translate between UMI codes and ZigBee Smart Energy data objects.
- A wireless M-bus module may translate between UMI codes and M-bus or DLMS (OBIS) data objects.
- An IEEE 802.15.4 module may translate between UMI codes and ANSI C12.19 data objects.

Every UMI device has a datasheet describing all device-specific functionality including the UMI codes/data objects; security schemes and roles, image transfer (s/w update), and physical characteristics. This information is proprietary to the UMI device manufacturer. They can choose whether to make this information publicly available, or only share it with selected partners under CDA.

Note that the UMI interface is open, but the data objects in UMI devices are not. This is an important point that should make the UMI standard more commercially attractive to many manufacturers.

Subject: UMI® (Universal Metering Interface) Overview

8 Benefits

8.1 Comprehensive solution

UMI specifies a defined interface for electrical, mechanical and software connections inside a smart energy meter. Smart meter manufacturers can include a number of UMI connectors in their products as a way of hosting the different modules that may be required. UMI supports advanced metering infrastructure with modules for the home area network, remote meter reading and communication between meters; thereby integrating smart metering for electricity, gas and other sources of energy.

UMI is a complete architecture within a product that interfaces with the core product functions (in a meter this is the metrology and display) to support communications using the OSI seven layer model for network protocols. Each UMI module includes a microcontroller running a UMI software stack to manage metering data exchanged using standards such as DLMS, ZigBee Smart Energy or IP networking. UMI modules can act as a bridge between heterogeneous networks thus allowing smart metering data to be transferred between different communication links.

8.2 Device Manufacturers

UMI has been designed with the metering industry's stringent requirements in mind; it is a low cost, low power interface with a form factor for modules that will fit comfortably inside a modern energy meter.

Modules and Host products can be developed, manufactured and marketed independently. Manufacturers of modules benefit from the larger market created by standardising the module across the range of Smart Energy devices. Manufacturers of Smart Energy devices benefit from the competition of multiple suppliers.

Typically the Smart Energy device manufacturer will customise the module with the market specific functionality including mapping of the devices data objects to the required data standard (e.g. DLMS, ZSE or ANSI C12.19). UMI does not prescribe the data objects in a device. Manufacturers can define these according to their products functionality and then choose which other organisations they share this with. This ensures manufacturers are free to differentiate their products based on functionality and features and control which modules will work in their product..

UMI incorporates security features to encrypt communications and prevent unauthorised access to the products data (in a meter this is the metrology and billing data). A process of authentication within UMI binds a module to the host product preventing unapproved modules being used and detecting tamper events. It is also a

Subject: UMI® (Universal Metering Interface) Overview

robust interface that protects against data errors and provides the inherent reliability required for this kind of application.

The module size and power supply options are suitable to support a wide range of Wireless HAN, Wireless WAN and Wired communications standards.

8.3 Energy Suppliers

Energy companies and Meter Asset Providers can benefit from lower unit costs and fewer single-source products by specifying that Meters and Communications modules must be UMI-compliant. UMI-enabled (or UMI-inside !) metering devices are more future-proof, which will reduce stranded assets.

8.4 Smart meter rollouts

Smart meter rollouts are planned for many countries. They are all being delayed because:

- People don't want to install anything until everything is specified.
- It is too hard to specify everything without empirical evidence and feedback from large installations (> 100k).
- Consequently people are too cautious and everything gets delayed. "Perfection is the enemy of the good !".

A successful smart meter rollout is likely to consist of :

- Revolutionary rollout first. This will solve 80% of the problem. The solution must contain technical hooks and interfaces to enable growth after the rollout.
- Then evolutionary growth. This will allow the remaining 20% of the problem to be solved over time after the rollout.

UMI is an important enabler to support the above model. It means that :

- Smart-ready meters can be installed now (e.g a UMI-enabled gas meter with a valve but no communications module fitted). Communications modules can be installed in the field later (at the same time as the home gateway is installed), when the communications standards have been chosen.
- Where the communications standards may change during the lifetime of the meter the communications module can be changed. Services may become obsolete or Wide Area communications providers may change and have a different network. An example of this is the planned UK roll-out.

Subject: UMI® (Universal Metering Interface) Overview

9 UMI Software

The UMI Specifications provide all the information required to fully develop UMI compliant products.

The UMI software from Cambridge Consultants provides a pre-existing implementation of the UMI functionality which can be used to accelerate and de-risk a Smart meter development. This software is a chargeable item is licensed alongside our design services. Please contact us on umi@cambridgeconsultants.com for further information.

The UMI software implements all of the UMI link layer and application layer protocol and presents a clean interface for the application developer. The application developer does not need to understand the details of the UMI protocol. They only need to understand the UMI API.

The UMI protocol and Stack were designed with smart metering devices in mind. Smart metering devices are typically cost sensitive and produced in high volume. To support this, the stack has a small memory footprint and is very efficient. With application-specific build-time configuration of the library, the footprint can be reduced further for simple applications.

The software is independent of the target platform. It can be ported to small 8-bit embedded processors yet has a sufficiently rich interface to be suitable for use on devices such as PCs, PDAs and laptops. The library makes no assumptions about operating systems and can be used with an operating system or “bare-metal”.

In terms of reliability, the library is field-proven, secure and qualified against the UMI compliance tests.

Below is a block diagram showing the software partitioning in a meter with UMI and the possible source/owners for different parts of this software.

Subject: UMI® (Universal Metering Interface) Overview

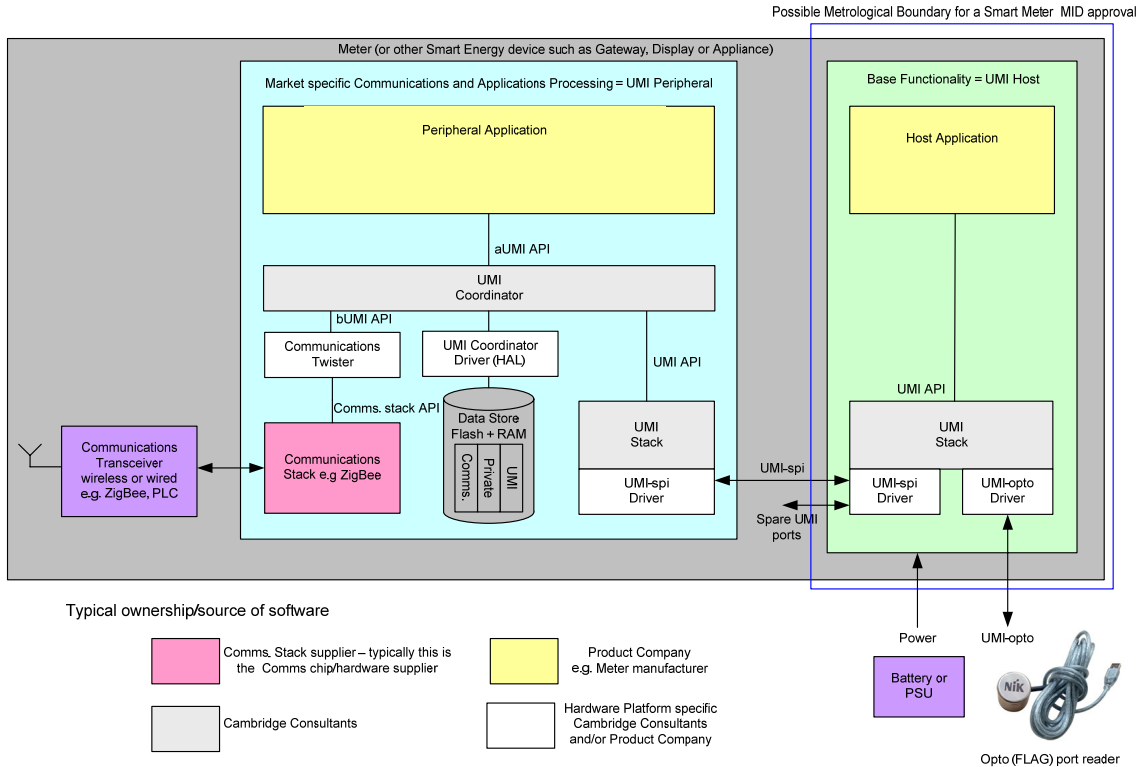

There are two separate components of the UMI software

- 1) UMI Stack: this implements the link and application layers of the UMI protocol and provides a defined API for the application developer. The UMI stack is used in both Host and Peripheral devices.
- 2) UMI Coordinator: provides a standard set of functions including the management of data storage and generic UMI functions. It provides a fixed API to the Peripheral application enabling the maximum reuse of the application software between different Peripheral designs. The UMI coordinator is used in UMI Peripherals and is an optional component. Please contact Cambridge Consultants to discuss your requirements.

In the software partitioning shown above the product manufacturer can choose which Smart device functionality is located on the Peripheral and which is located on the Host. This partitioning can be chosen based on the target markets, known stable specifications vs. areas of functionality which will change and future product plans and roadmap.

Subject: UMI® (Universal Metering Interface) Overview

10 What next ?

We hope that you will include the UMI ports in your new smart metering products (UMI Hosts) and communications modules (UMI Peripherals). UMI Peripherals will be available for wireless and wired LAN and WAN interfaces (e.g ZigBee, Wireless M-Bus, GPRS, PLC (Power Line Communications)).

If you would like to know more about UMI, the UMI software stack and UMI test services please contact :

- umi@CambridgeConsultants.com

or visit

- www.CambridgeConsultants.com/umi

Cambridge Consultants is a multi-disciplinary engineering design consultancy with 300 people in Cambridge UK and 40 in Boston USA. We sell engineering design services and technology intellectual property. In 2010 we celebrated our 50th anniversary.

You can find out more about the company at www.CambridgeConsultants.com

We are available to help you develop your UMI-compliant products.